

**Important:** Read all instructions including wiring and mechanical details before the start of the installation.

**Important:** Install in accordance with the local and national building and electrical codes.

**Note:** Suspended Mounting Systems are designed for installation post ceiling preparation completion

**WARNINGS:**

- **Shock hazard!** Power connections must be connected to building ground via ground wire before connecting to main supply power.

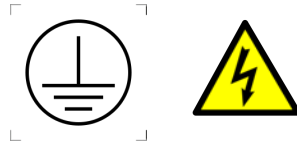

- Disconnect or turn off power supply before attempting any installation maintenance or servicing operations.(example of draft installation documentation warning section)

## R1 - Recessed Junction Box Power Kit - Flat Ceiling

### Contents:

1. Spanner Bar with ground wire terminal ring attached
2. Power cord provided as per specified power drop attached to luminaire
3. 6.5" aesthetic canopy cover with power hole access
4. Cover plate shield barrier
5. Slip ring to allow for lowering canopy and cover plate for access for splice inspection
6. Coupler to fasten to  $\frac{1}{4}$  - 20 PEM stud in spanner bar
7. 2 x #10 phillips hardware to secure spanner bar (by others with j-box)
8. 2 x #6-32 philips screws to secure cover plate barrier
9. Suspension cable 1mm diameter to suspend luminaire via coupler.

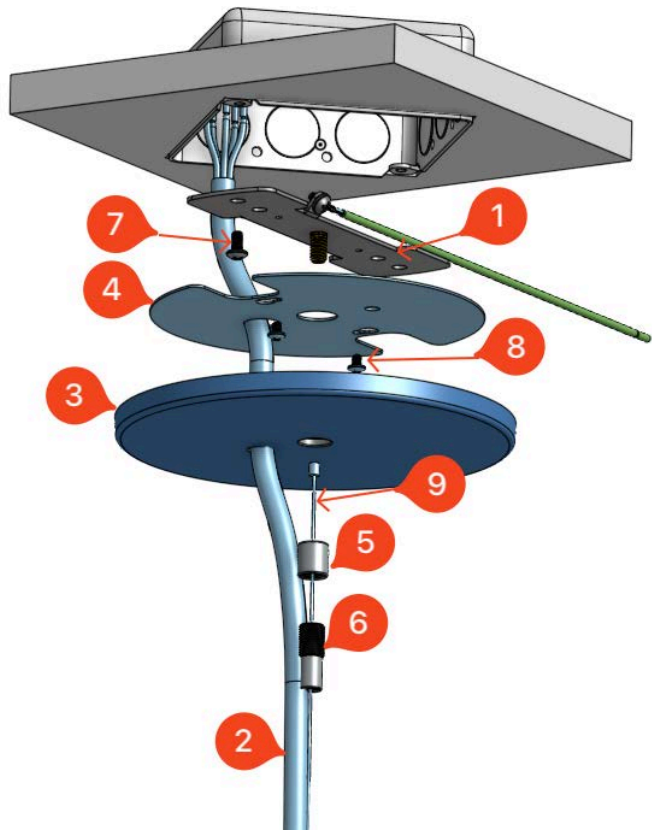

As installed

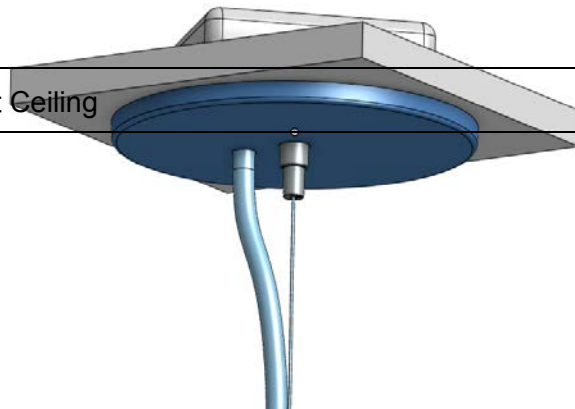

R1 - Recessed Junction Box Power Kit - Flat Ceiling

Steps to show the supply cord and cable assembly were installed/wired with the canopy installed.

**WARNINGS:**

Ensure you have all parts and hardware to complete the installation.

- **Shock hazard!** Power connections must be connected to building ground via ground wire before connecting to main supply power.

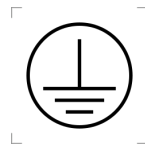

- Disconnect or turn off power supply before attempting any installation maintenance or servicing operations. (example of draft installation documentation warning section)

### R1 - Power Mounting Installation Steps

1. Secure spanner bar to junction box with 2x#10 screws or appropriate hardware.

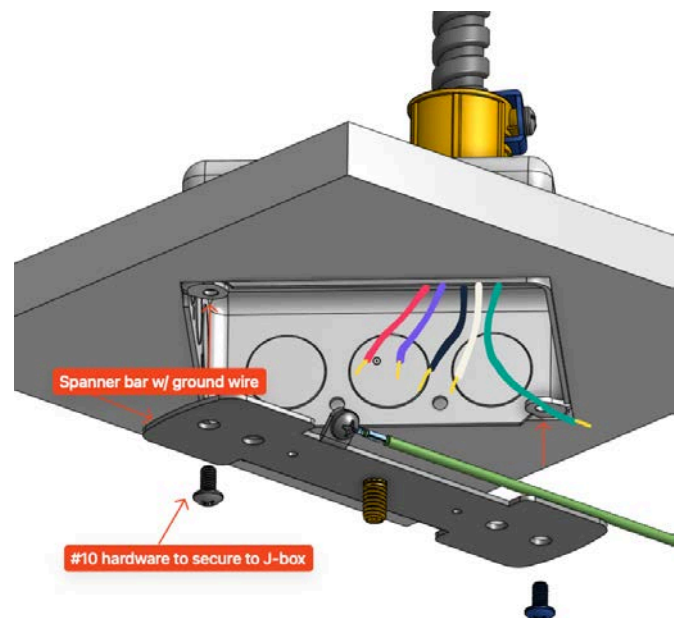

- Secure spanner bar and connect ground wire first with provided 3 lever WAGO. Tuck into J-box cavity.

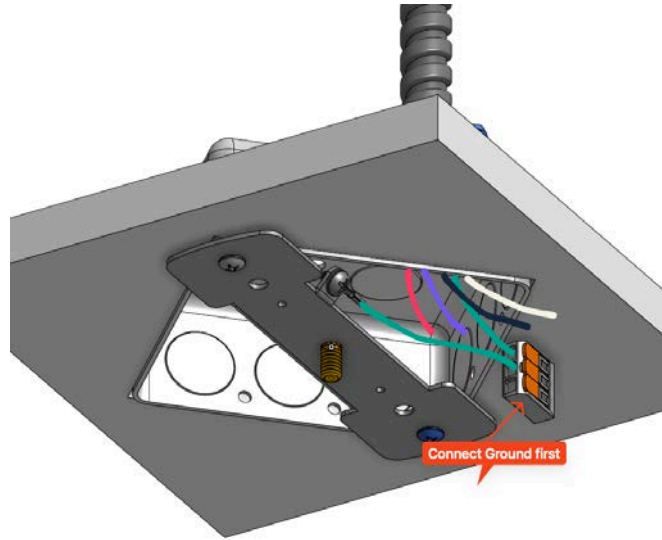

- Install the coupler and suspension cable to  $\frac{1}{4}$ -20 stud on the spanner bar.

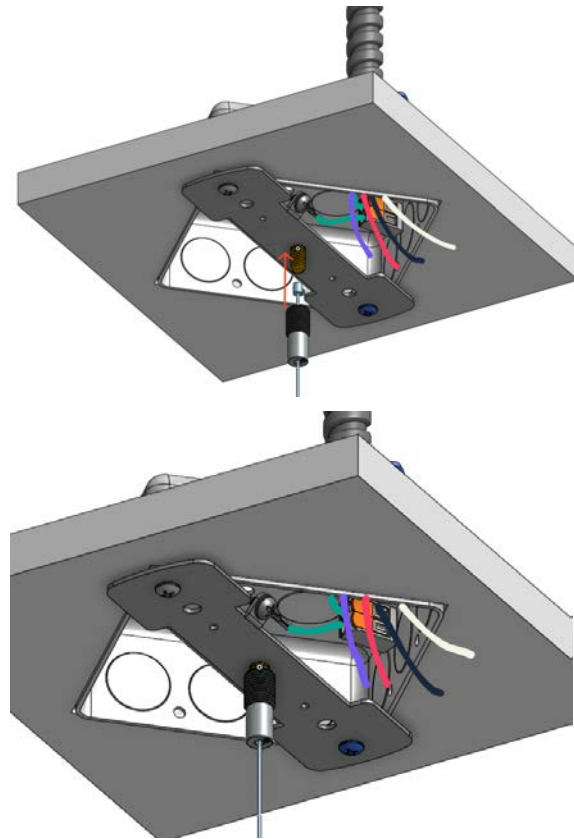

4. Feed suspension cable through steel cover plate, 6.5" canopy, and the slip ring.
5. Suspend fixture to suspension wire at fixture end onto provided gripper to allow for power cord access. (Other end of fixture may be held by colleague or suspended on other mount point)

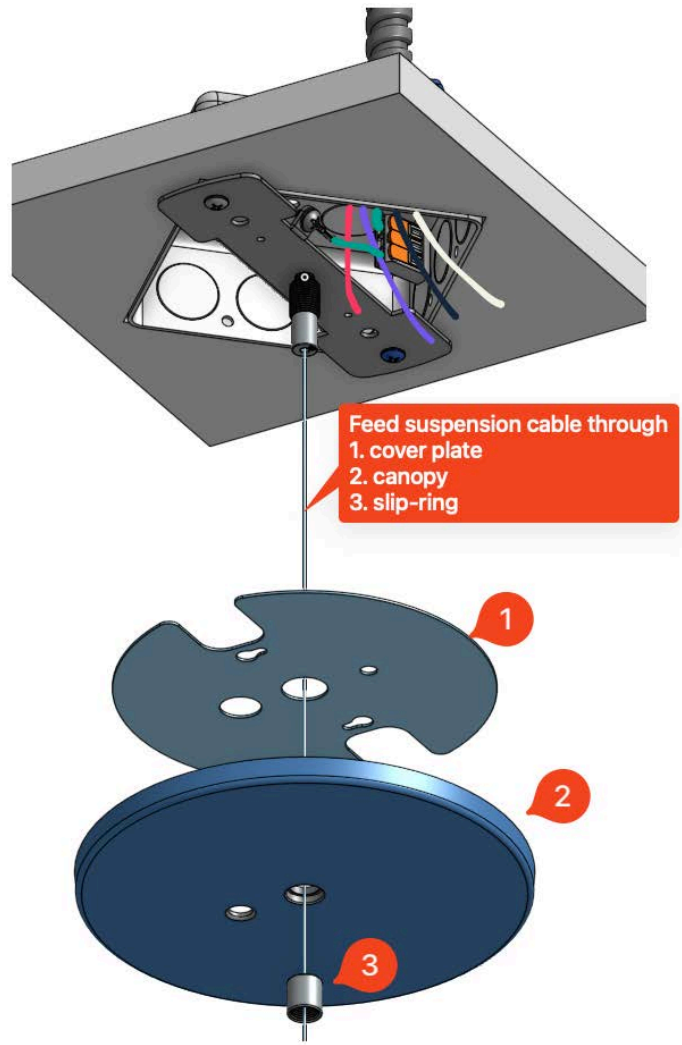

6. Remove 2- lever WAGOs from power cord. Pass power cord through canopy and cover plate.
7. Tie power cord into an overhand knot.

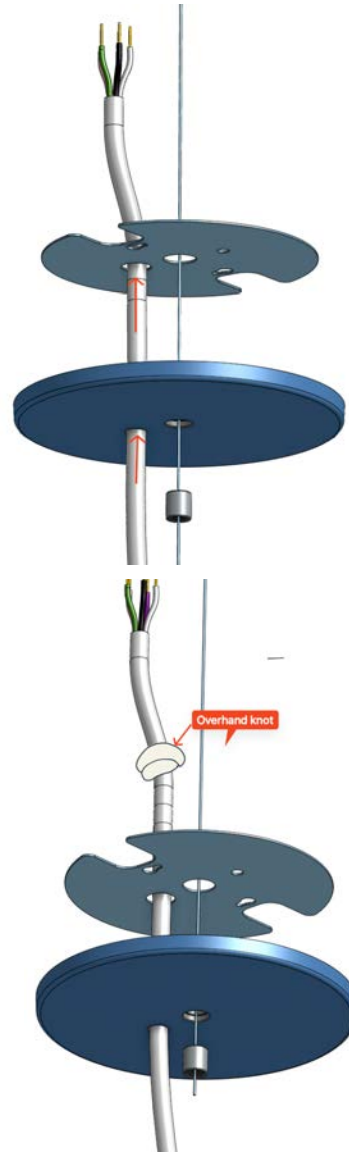

8. **Shock hazard!**  
Ensure power supply is turned off before attempting any installation maintenance or servicing operations.

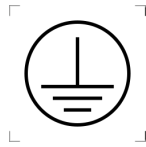

- Re-attach 2- lever WAGOs power cord.
- Ensure to make ground connection first.
- Proceed to make electrical connections at J-box to supply connection.

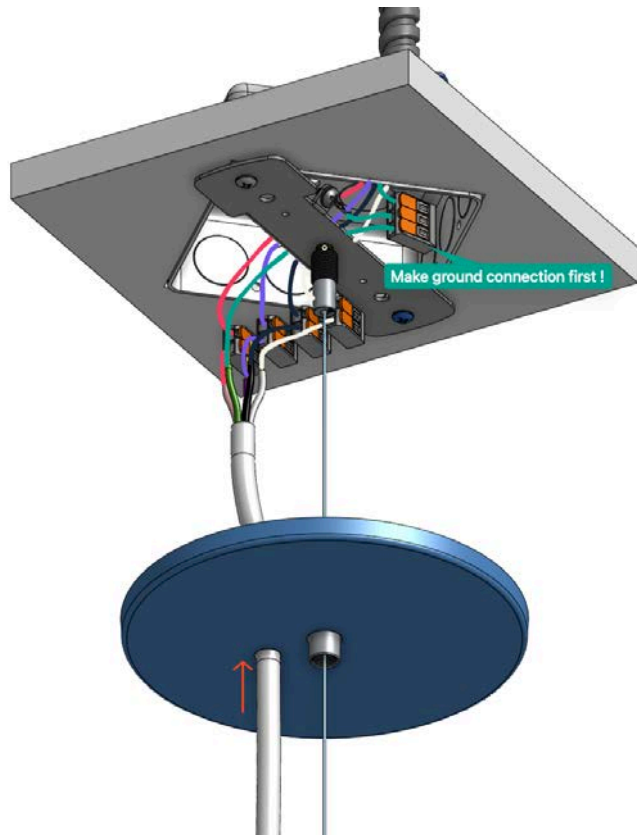

9. Feed connections into the J-box cavity and secure cover plate with provided #6-32 phillips screws to the spanner bar.

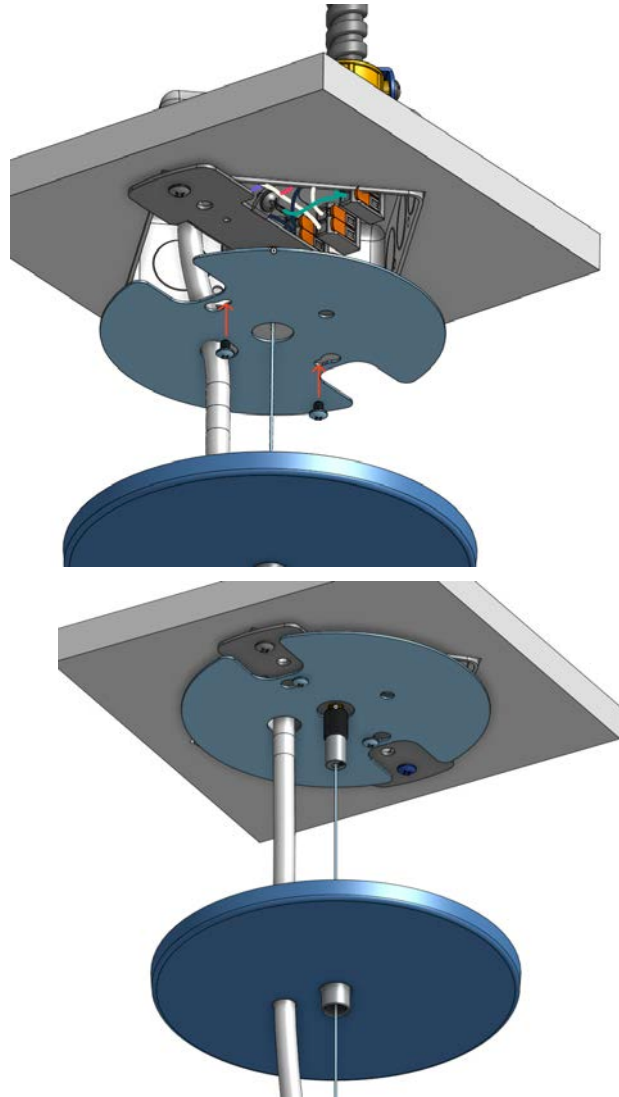



- Final step to raise slip ring and canopy to secure to coupler to cover the plate and spanner bar.

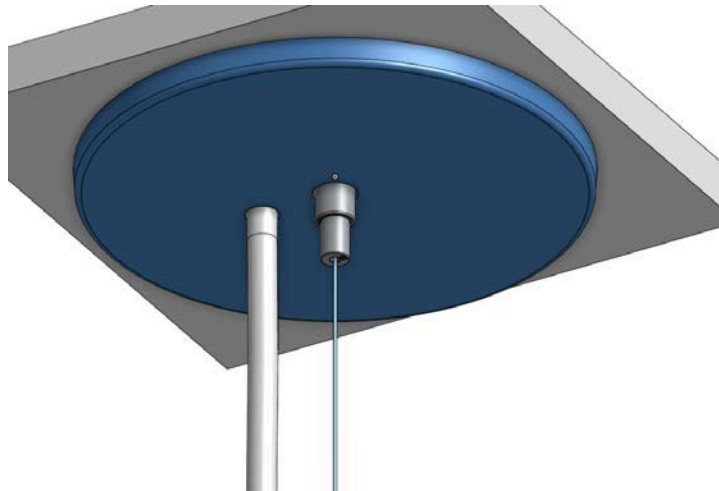

## R2 - Recessed Surface Power Mount Kit - Sloped Ceiling

### Contents:

- Spanner Bar with ground wire terminal ring attached
- Power cord provided as per specified power drop attached to luminaire
- 6.5" aesthetic canopy cover with power hole access
- Cover plate shield barrier
- Slip ring to allow for lowering canopy and cover plate for access for splice inspection
- Coupler to fasten to 1/4 - 20 PEM stud in spanner bar
- Slope coupler mates with item 6
- 2 x #10 phillips hardware to secure spanner bar (by others with j-box)
- 2 x #6-32 philips screws to secure cover plate barrier
- Suspension cable 1mm diameter to suspend luminaire via coupler.

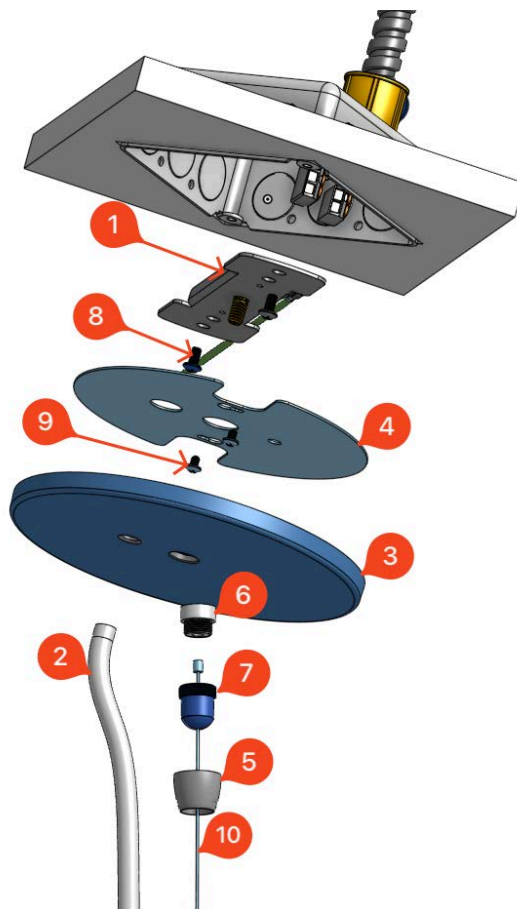

As installed

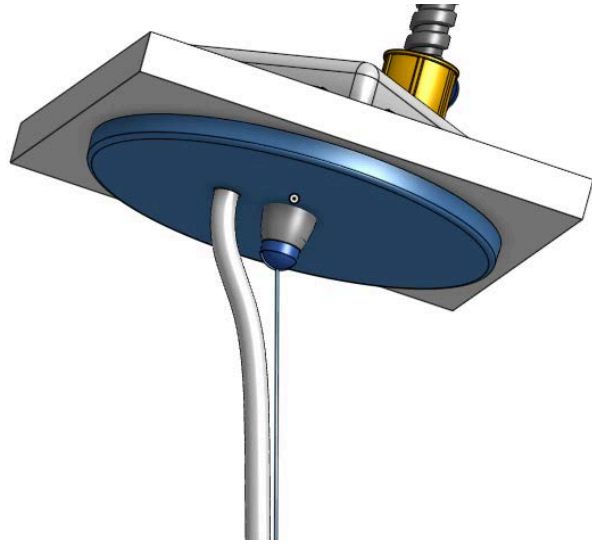

Steps to show the supply cord and cable assembly were installed/wired with the canopy installed.

Ensure you have all parts and hardware to complete the installation.

## WARNINGS:

- **Shock hazard!** Power connections must be connected to building ground via ground wire before connecting to main supply power.

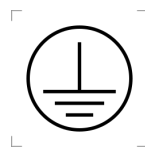

- Disconnect or turn off power supply before attempting any installation maintenance or servicing operations.(example of draft installation documentation warning section)

**R2 - Power Mounting Installation Steps**

1. Secure spanner bar to junction box with 2x#10 screws or appropriate hardware.
2. Connect ground wire to building ground with provided 3-lever WAGO and tuck into J-box cavity.

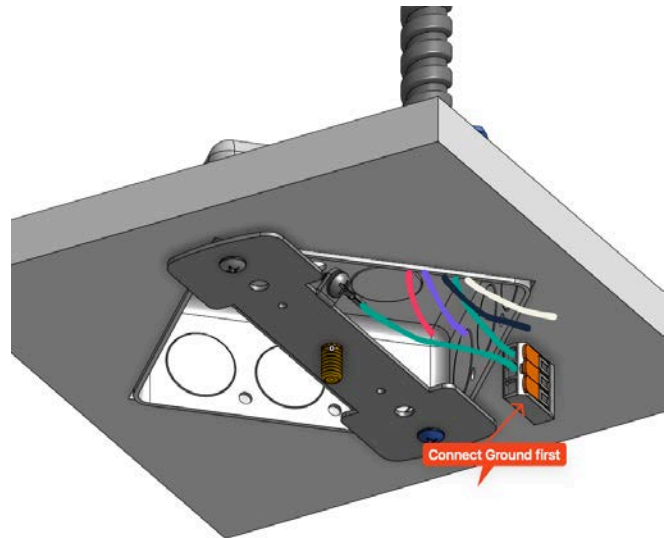
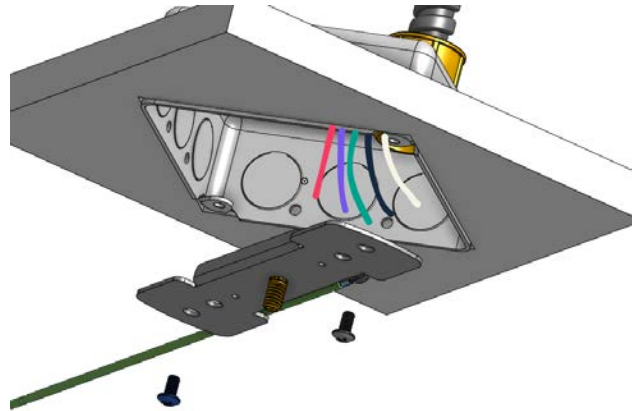

3. Install the coupler(s) and suspension cable to  $\frac{1}{4}$ -20 stud on the spanner bar.  
Note: it's a two piece coupler system.  
Feed suspension cable with crimp through item 7. Thread item 7 onto item 6. Thread item 6 onto  $\frac{1}{4}$ -20 stud.

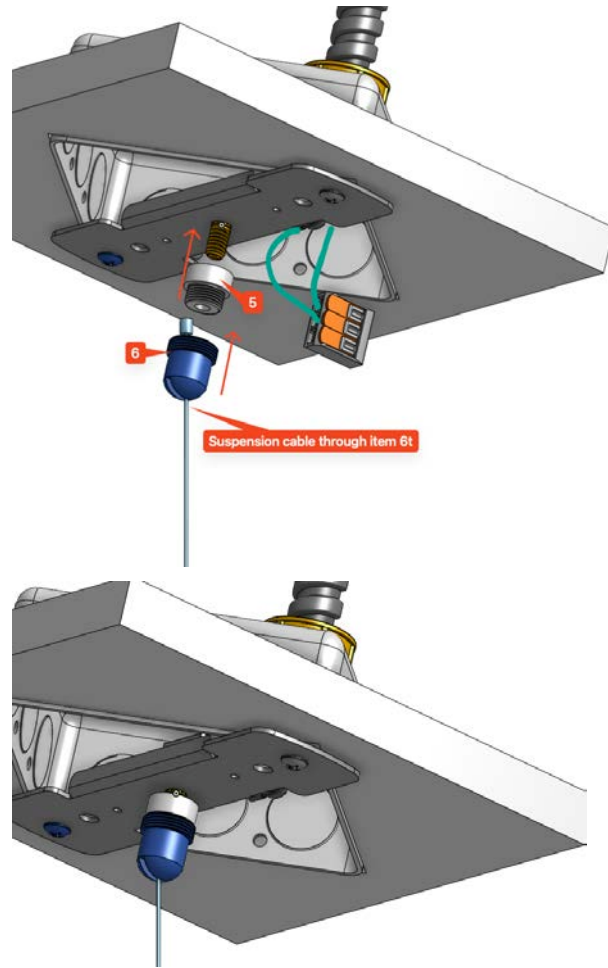

4. Feed suspension cable through steel cover plate, 6.5" canopy, and the slip ring.
5. Suspend fixture to suspension wire at fixture end into installed gripper to allow for power cord access. (Other end of fixture may be held by colleague or suspended on other mount point)

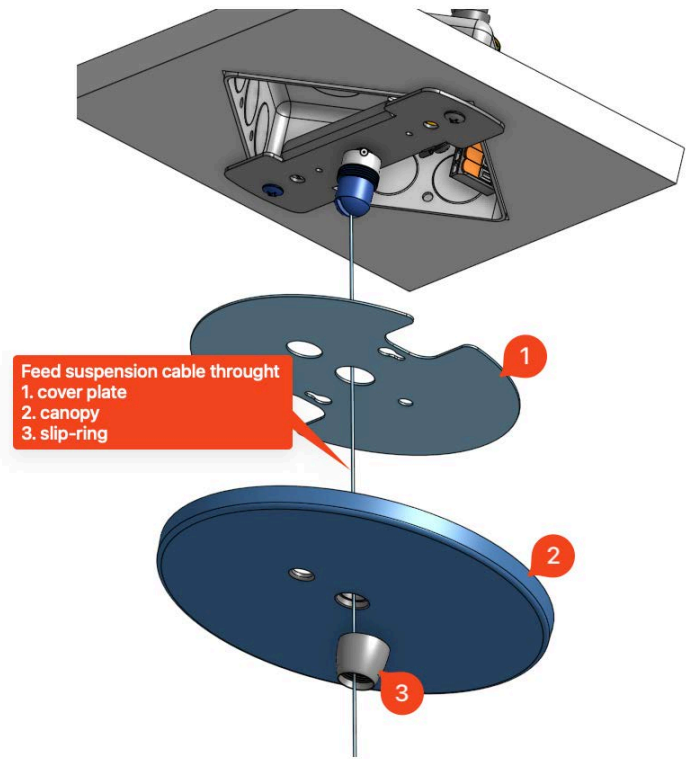

6. Remove 2- lever WAGOs from power cord. Pass power cord through the canopy and cover plate.
7. Tie power cord into an overhand knot.

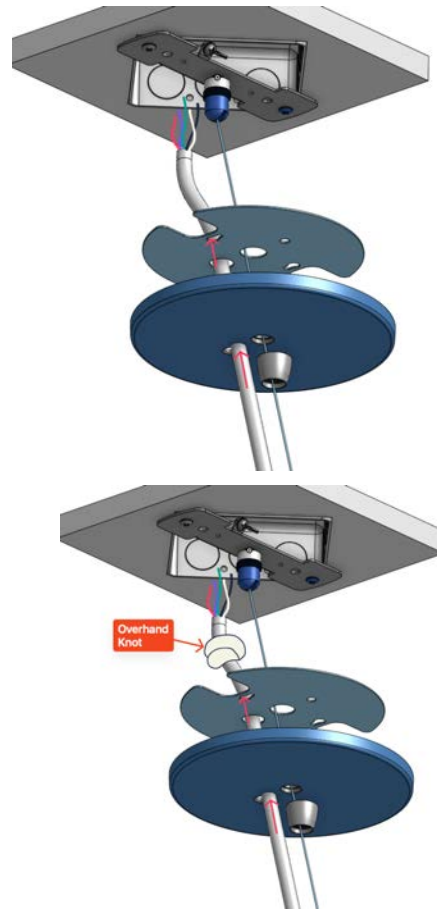

## 8. Shock hazard!

Ensure power supply is turned off before attempting any installation maintenance or servicing operations.

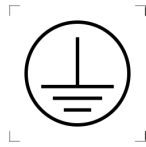

- Re-attach 2- lever WAGOs power cord.
- Ensure to make ground connection first.
- Proceed to make electrical connections at J-box to supply connection.

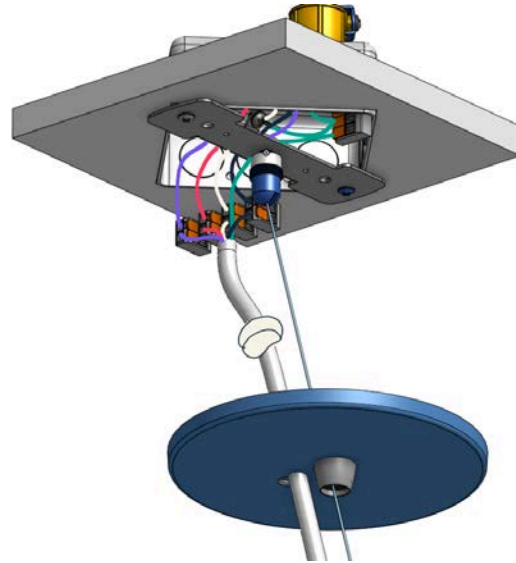

9. Feed connections into the J-box cavity and secure cover plate with provided #6-32 phillips screws to the spanner bar.

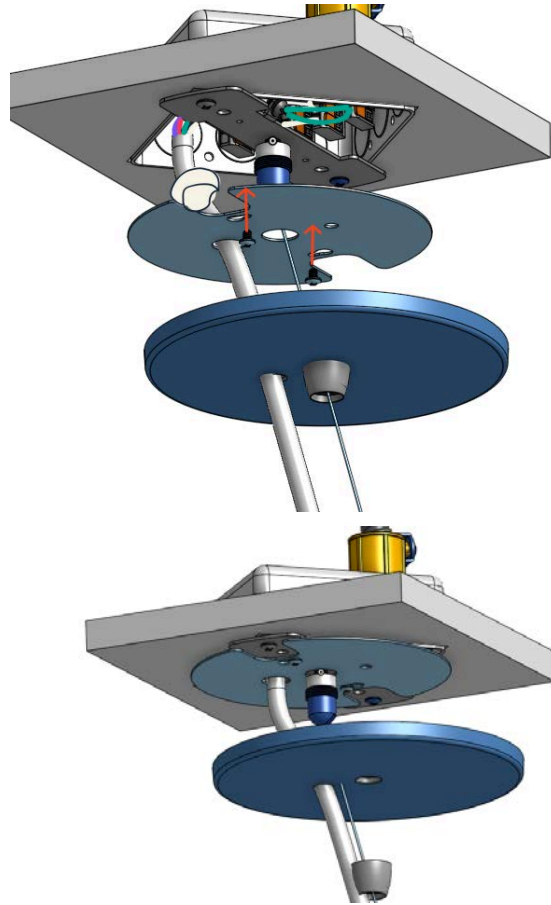

10. Final step to raise slip ring and canopy to secure to coupler to cover the plate and spanner bar.

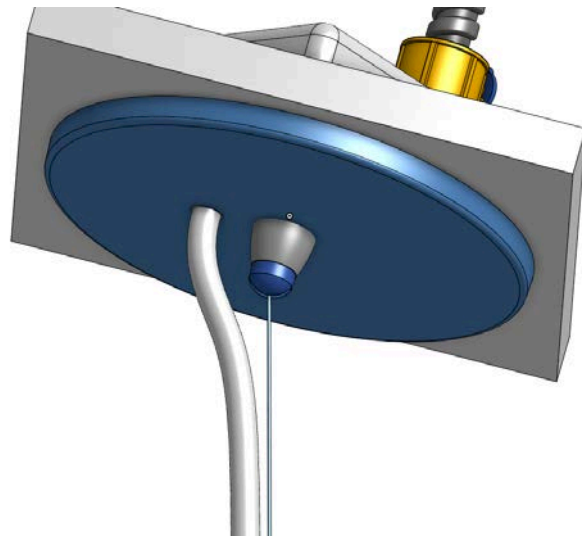



## R1 - Recessed Surface Non-Power Mount Kit

### Contents:

1. 2.5 inch canopy
2. 1mm diameter suspension cable
3. ¼-20 griplock coupler

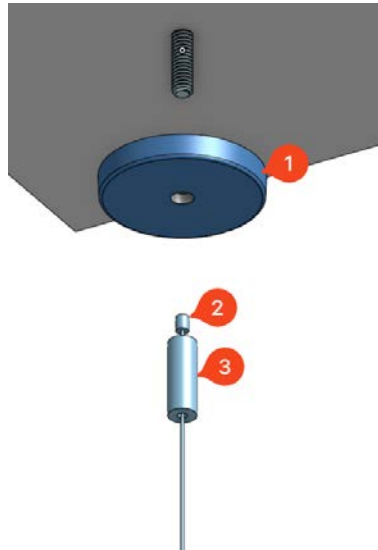

### As installed

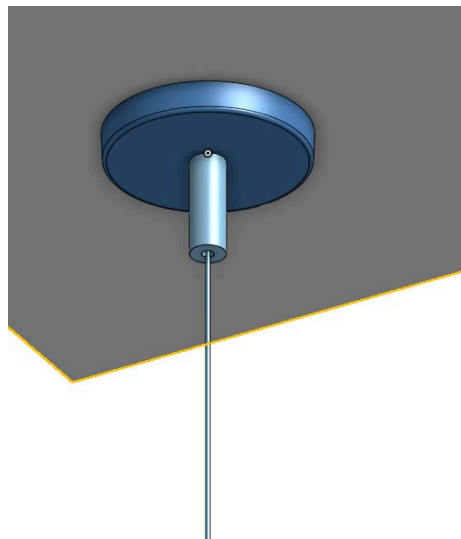

### R1 - Non-Power Mounting Installation Steps

1. Install ¼-20 stud in correct location as per layout drawings.  
*Note: Ensure to leave enough threaded stud exposed to allow or coupler of thread onto stud once canopy is installed.*
2. Feed suspension cable through coupler
3. Install canopy on to stud
4. Thread coupler with suspension cable installed onto stud.

5. Done

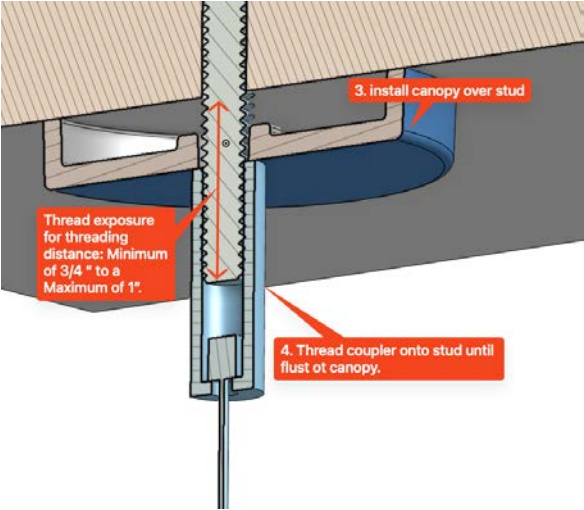
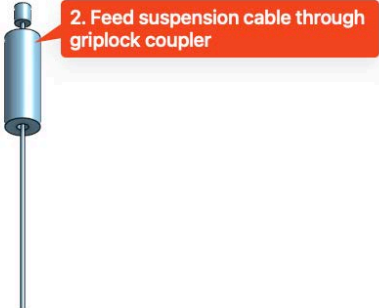
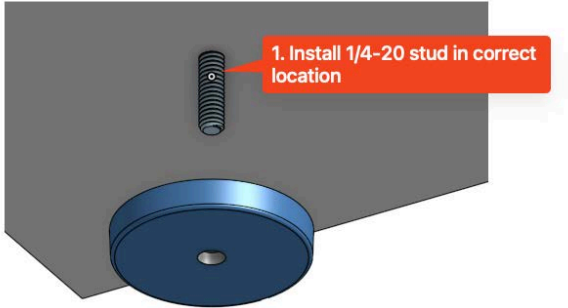

R2 - Recessed Surface Non-Power Mount Kit - Sloped Ceiling

Contents:

1. 2.5 inch canopy
2. 1/4-20 griplock coupler
3. Coupler for suspension cable
4. Slip-ring to hold canopy
5. 1mm diameter suspension cable

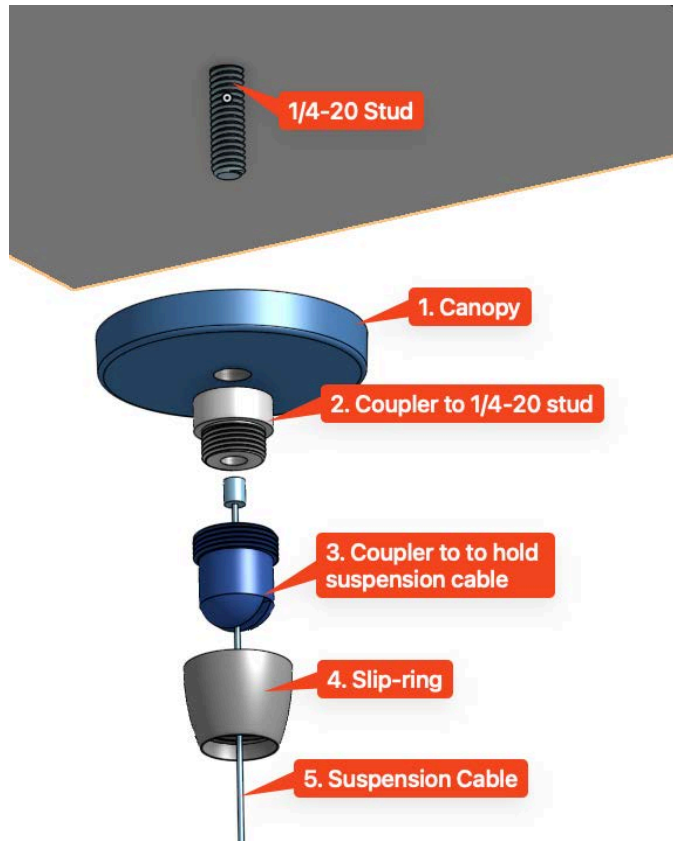

As installed

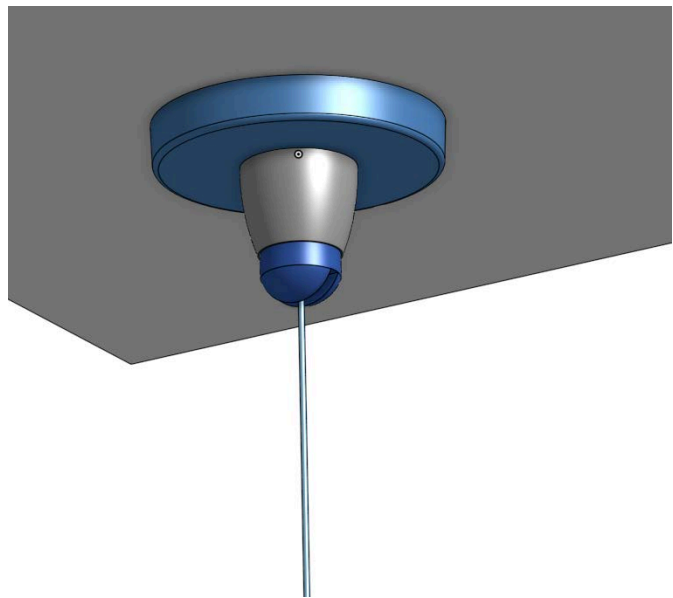

## R2 - Non-Power Mounting Installation Steps

1. Install 1/4-20 stud in correct location as per layout drawings.  
*Note: Ensure to leave enough threaded stud exposed to allow or coupler of thread onto stud once canopy is installed.*

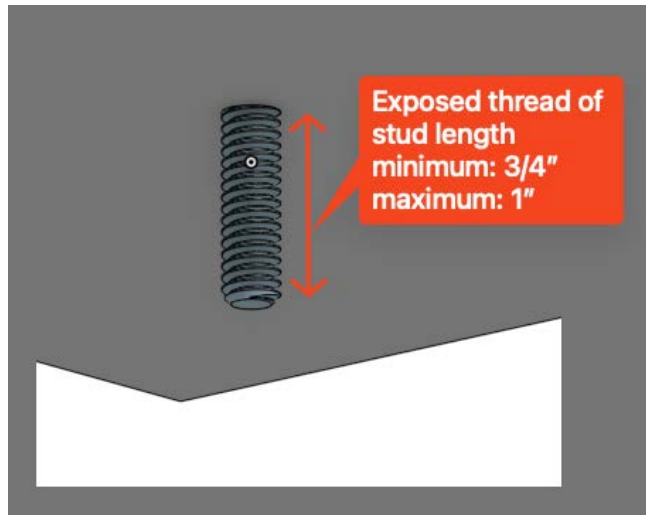

2. Install canopy on to stud
3. Feed suspension cable through cable coupler and slip-ring
4. Thread stud coupler onto stud

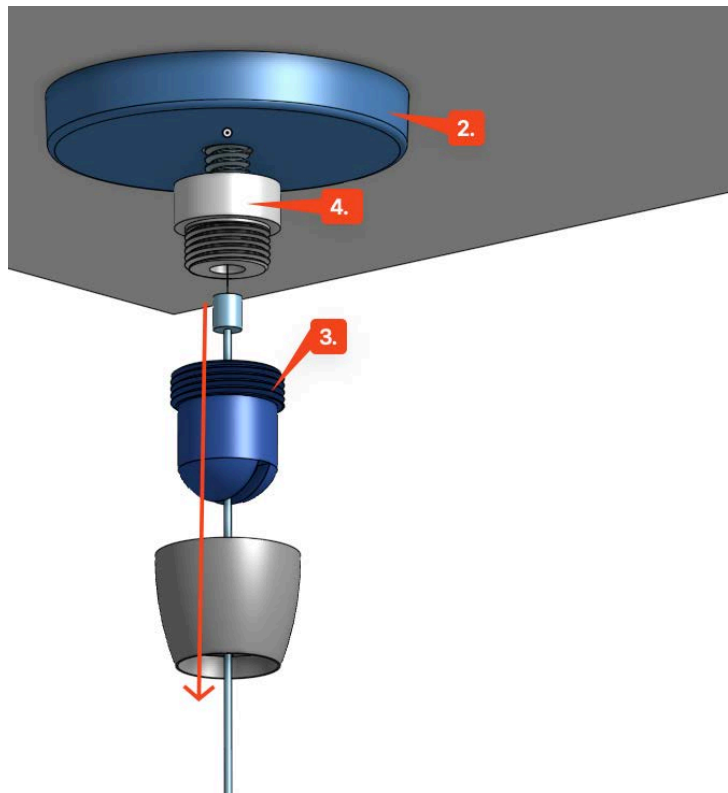

5. Thread cable coupler onto stud coupler
6. Thread slip-ring onto suspension cable coupler
7. Done

